

vtech®

Parent's Guide

**Toot-Toot
Friends™**

2-in-1 Fire Station



91-003871-001^{UK}

VTech understands that a child's needs and abilities change as they grow and with that in mind we develop our toys to teach and entertain at just the right level...

vtech Baby

Toys that will stimulate their interest in different textures, sounds and colours

I am...

...responding to colours, sounds and textures

...understanding cause and effect

...learning to touch, reach, grasp, sit-up, crawl and toddle

Birth-36 months



Pre-School

Interactive toys to develop their imagination and encourage language development

I want...

...to get ready for school by starting to learn the alphabet and counting

...my learning to be as fun, easy and exciting as can be

...to show my creativity with drawing and music so my whole brain develops

3-6 years



Electronic Learning Computers

Cool, aspirational and inspiring computers for curriculum related learning

I need...

...challenging activities that can keep pace with my growing mind

...intelligent technology that adapts to my level of learning

...National Curriculum based content to support what I'm learning at school

4-10 years



To learn more about this and other VTech® products, visit www.vtech.co.uk

INTRODUCTION

It's time to save the day with the **Toot-Toot Friends™ 2-in-1 Fire Station** by **VTech®**! This fun packed fire station can transform between a fire station and a fire engine for lots of role-play fun. Help Finley and Freya, the fire fighters, rescue the man off the roof or put the shop fire out!

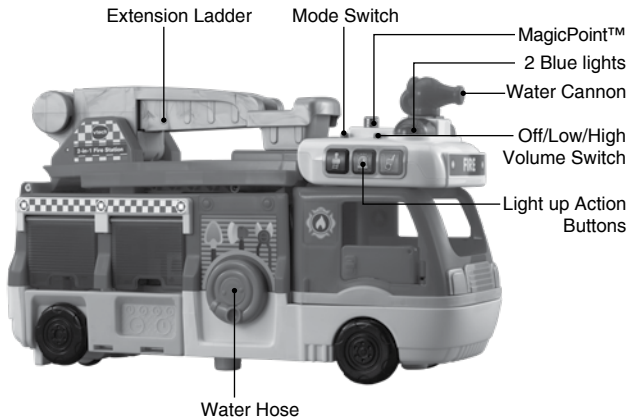

Fire Fighter
Freya



Fire Fighter
Finley



Mini Fire Engine



Helicopter



Detachable
Ladder

INCLUDED IN THIS PACKAGE

NOTE: This toy is not intended for teething.

This toy is not intended for playing in water.



• Fire Fighter Freya



• Fire Fighter Finley



• Mini Fire Engine



• Helicopter



• Detachable Ladder

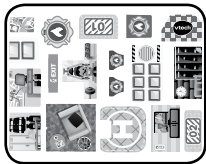

• Label Sheet



• 2-in-1 Fire Station

• Parent's Guide

WARNING

All packing materials such as tape, plastic sheets, packaging locks, removable tags, cable ties and packaging screws are not part of this toy and should be discarded for your child's safety.

NOTE

Please keep this Parent's Guide as it contains important information.

Removing the Packaging Locks:

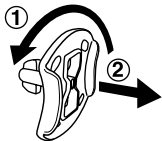

① Rotate the packaging locks anticlockwise 90 degrees.

② Pull out the packaging locks and discard.

Note: Please cut and discard the plastic tie between the door and the front of the Fire Engine before playing with the unit. This plastic tie is not part of the product and should be discarded for your child's safety.

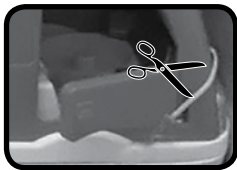

GETTING STARTED

Battery Removal and Installation

1. Make sure the unit is turned Off.
2. Find the battery cover located on the bottom water cannon and use a screwdriver to loosen the screw and open the battery cover.
3. Remove old batteries by pulling up on one end of each battery.
4. Install 2 new AA (AM-3/LR6) batteries following the diagram inside the battery box.
5. Replace the battery cover and tighten the screw to secure.

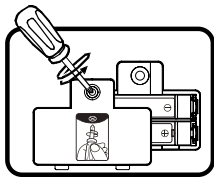

BATTERY NOTICE

- Use new alkaline batteries or fully charged NI-MH (Nickel Metal-hydride) rechargeable batteries for best performance.
- Use only batteries of the same or equivalent type as recommended.
- Do not mix different types of batteries: alkaline, standard (carbon-zinc) or rechargeable, or new and used batteries.
- Do not use damaged batteries.
- Insert batteries with the correct polarity.
- Do not short-circuit the battery terminals.
- Remove exhausted batteries from the toy.
- Remove batteries during long periods of non-use.
- Do not dispose of batteries in fire.
- Do not charge non-rechargeable batteries.
- Remove rechargeable batteries from the toy before charging (if removable).
- Rechargeable batteries are only to be charged under adult supervision.

Disposal of batteries and product



The crossed-out wheellie bin symbols on products and batteries, or on their respective packaging, indicates they must not be disposed of in domestic waste as they contain substances that can be damaging to the environment and human health



The chemical symbols Hg, Cd or Pb, where marked, indicate that the battery contains more than the specified value of mercury (Hg), cadmium (Cd) or lead (Pb) set out in Battery Directive (2006/66/EC).

The solid bar indicates that the product was placed on the market after 13th August, 2005.

Help protect the environment by disposing of your product or batteries responsibly.

For more information, please visit:

www.recycle-more.co.uk

www.recyclenow.com

LABEL APPLICATION

Please securely stick the labels to the playset as indicated below:



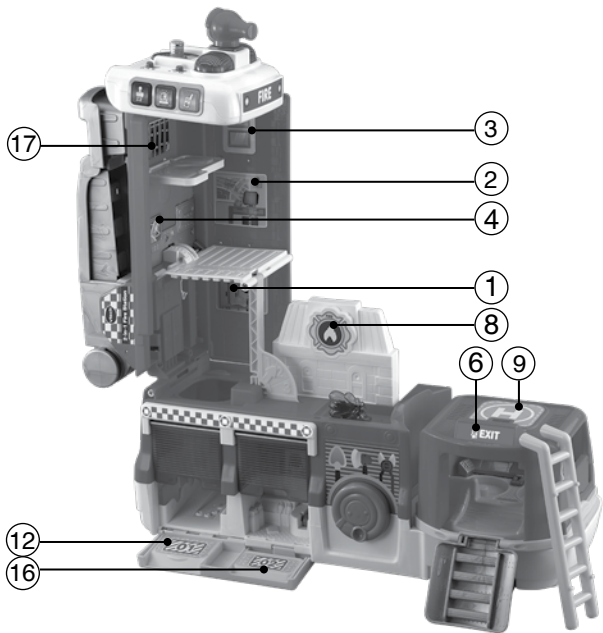

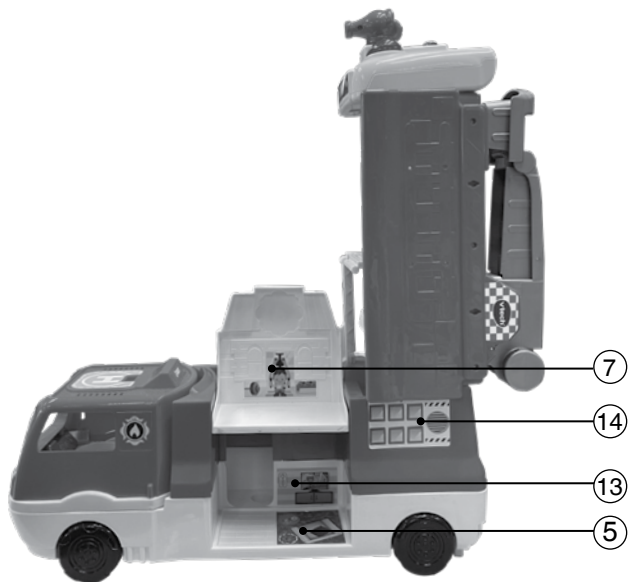



NOTE

This product is in Try Me mode in the packaging. To activate Normal Play mode, please follow these steps.

1. Turn the unit **On**.
2. Place one **Fire Fighter** on the **MagicPoint™**.
3. When you hear two short sounds, normal game play has been activated.



PRODUCT FEATURES

1. Off/Low/High Volume Switch

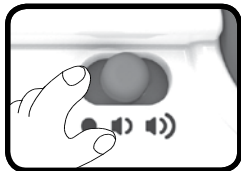
To turn the unit **On**, slide the **Off/Low/High Volume Switch** to either the Low volume  or High volume  position. To turn the 2-in-1 Fire Station **Off**, slide the switch to the **Off**  position.



2. Mode Switch

Slide the **Mode Switch** to the left to enter Music & Sounds mode . Slide the **Mode Switch** to the middle to enter Explore & Train mode . Slide the **Mode Switch** to the right to enter Rescue Mission mode .

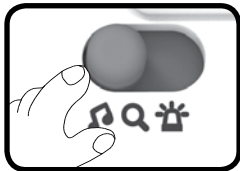

3. Action Buttons

Press the three **Action Buttons** to learn about colours, sounds and how to use rescue gear to carry out the rescue missions.



4. **Water Cannon**

Press the **Water Cannon** to help put out the fire.

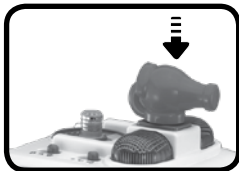

5. **MagicPoint™**

Place the characters onto the **MagicPoint™** location to hear fun responses.



6. **Transformation**

The playset can be transformed from a Fire Engine to a Fire Station and back again. Enjoy fun role-play in both modes.

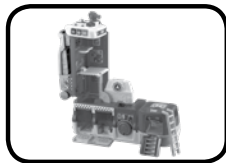

- Lift up the top section of the engine.



- The cab of the engine twists anticlockwise.



- Lift the doors and pull down the side of the engine.

7. Automatic Shut-Off

To preserve battery life, the **2-in-1 Fire Station** will automatically shut off after several minutes without input. The unit can be turned on again by sliding the **Off/Low/High Volume Switch** to the Low volume position or High volume position, or by sliding the **Mode Switch** to **Music & Sounds Mode**, **Explore & Train Mode** or **Rescue Mission Mode** position.

ACTIVITIES

1. Mode 1: Music & Sounds Mode 🎵

Slide the **Mode Switch** to the left position to enter this mode. Press the three **Action Buttons** to hear sound effects and phrases. Place the characters onto the **MagicPoint™** location to hear melodies and songs.



2. Mode 2: Explore & Train Mode 🔍

Slide the **Mode Switch** to the middle position to enter this mode. Press three **Action Buttons** to learn about colours, facts about fire engines and firefighting. Place the characters onto the **MagicPoint™** location to hear the characters talk, introduce themselves and more.



3. Mode 3: Rescue Mission Mode 🚒

Slide the **Mode Switch** to the right position to enter this mode. Press the **Action Buttons**, **Water Cannon** or place the characters onto the **MagicPoint™** to play training and rescue games in fire engine and fire station.



MOTOR SKILL DEVELOPMENT

1. Move the **Fire Fighters** workout room up to reveal more living space.

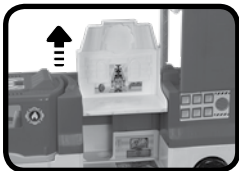

2. Drop a **Fire Fighter** through the opening and into the **Mini Fire Engine**.

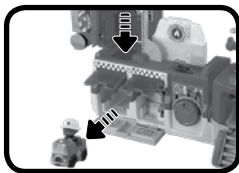

3. Put a **Fire Fighter** into the helicopter. Help is on the way!



4. Need more water? Spin the revolving **Water hose**.

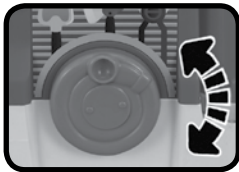

5. Put a **Fire Fighter** onto the **Extension Ladder** that can be raised and lowered.

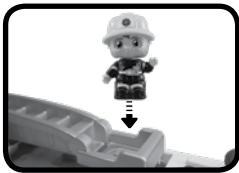

6. The **Detachable Ladder** stores on the fire engine.

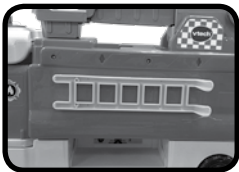

7. Flip the water splash during pretend training exercises.



8. Place the **Fire Fighters** in the driver's and passenger's seats.



9. Flip the bed down and place a **Fire Fighter** there to take a nap.



10. Pretend to fuel up the vehicles with the included petrol pump. If the petrol pump becomes detached, it can be easily snapped back into place.



11. The fire engine door opens and closes. If the door becomes detached, it can be easily snapped back into place.



MELODIES

1. Hot Cross Buns
2. Alouette
3. Jack and Jill
4. Oats, Peas, Beans and Barley Grow
5. Old King Cole
6. Polly Put the Kettle on
7. London Bridge
8. Ring Around a Rosy

SONG LYRICS

Song 1

Fire fighters, suit up!
We are fire fighters and we're here to help,
With our gear and our Fire Engine,
Help is on the way!

Song 2

To rescue, to rescue, with sirens and lights,
We'll help in any way, any day or any night!
To rescue, to rescue to help save the day,
Back to the station, back home to stay.

Song 3

Up, up in a big tree, a kitty did climb,
Now she's stuck up there, it's almost bedtime.
She's too high to reach, oh what to do?
Call the fire department, and we'll come rescue.

Song 4

Oh dear, where can the fire be?
Oh dear, where can the fire be?
Oh dear, where can the fire be?
Don't worry, we'll put it out!

Song 5

Helicopter can really fly,
Helicopter moves swift through the sky.
All the heroes on land and in air,
Work to help others because they care.

CARE & MAINTENANCE

1. Keep the product and its metal parts clean by wiping them with a slightly damp cloth.
2. Keep the unit out of direct sunlight and away from any direct heat sources.
3. Remove the batteries if the unit will not be in use for an extended period of time.
4. Do not drop the unit on a hard surfaces and do not expose the unit to moisture or water.

TROUBLESHOOTING

If for some reason the unit stops working or malfunctions while a character is on the **MagicPoint™**, please remove the character and place it back onto the **MagicPoint™**. If the unit still does not function, or if for some reason the unit stops working or malfunctions on its own, please follow these steps:

1. Turn the unit **Off**.
2. Interrupt the power supply by removing the batteries.
3. Let the unit stand for a few minutes, then replace the batteries.
4. Turn the unit **On**. The unit should now be ready to use again.
5. If the unit still does not work, install a new set of batteries.

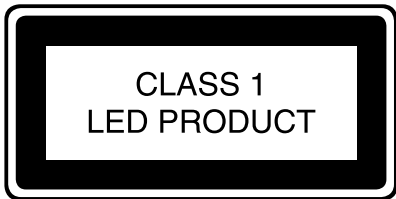

CONSUMER SERVICES

Creating and developing **VTech®** products is accompanied by a responsibility that we at **VTech®** take very seriously. We make every effort to ensure the accuracy of the information, which forms the value of our products. However, errors sometimes can occur. It is important for you to know that we stand behind our products and encourage you to call our Consumer Services Department with any problems and/or suggestions that you might have. A service representative will be happy to help you.

UK Customers:

Phone: 0330 678 0149 (from UK) or +44 330 678 0149 (outside UK)
Website: www.vtech.co.uk/support

Australian Customers:

Phone: 1800 862 155
Website: support.vtech.com.au

NZ Customers:

Phone: 0800 400 785
Website: support.vtech.com.au

PRODUCT WARRANTY/ CONSUMER GUARANTEES

UK Customers:

Read our complete warranty policy online at vtech.co.uk/warranty.

Australian Customers:

VTECH ELECTRONICS (AUSTRALIA) PTY LIMITED –
CONSUMER GUARANTEES

Under the Australian Consumer Law, a number of consumer guarantees apply to goods and services supplied by VTech Electronics (Australia) Pty Limited. Please refer to vtech.com.au/consumerguarantees for further information.

**Visit our website for more
information about our products,
downloads, resources and more.**

www.vtech.co.uk
www.vtech.com.au

